

## 9 STORAGE AND STABILITY

The QuickPick™ SML Plant DNA purification kits should be stored at room temperature. Magnetic Particles should not be frozen.

## 10 WARNINGS AND LIMITATIONS

The QuickPick™ SML Plant DNA purification kit is intended for research use only, and is not intended for use in human diagnostic or therapeutic procedures. Standard methods for preventing contamination with DNases during preparation of DNA must be taken. Precautions should also be taken to avoid contamination of opened vials. Do not pipet by mouth.

Plant DNA MagaZorb™ reagent, Wash Buffer and Binding Buffer contain 0.02 % sodium azide (NaN<sub>3</sub>) as a preservative. When in contact with acid or heavy metal ions, it forms a highly toxic gas. Preservatives such as NaN<sub>3</sub> are toxic if ingested. Do not pipet by mouth. Direct skin contact must be avoided. Appropriate precautions should be taken when handling these solutions.

## 11 DISCLAIMERS AND WARRANTIES

Bio-Nobile warrants that its products shall be free from defects in materials and workmanship and shall meet performance specifications if stored and used in accordance with the instructions for use, for a period up to the expiry date provided on the reagent package. This warranty does not cover normal wear and tear or misuse of the product. Bio-Nobile's obligation and the purchaser's exclusive remedy under this warranty is limited to replacement, at Bio-Nobile's expense, of any products defective in manufacture. In no event shall Bio-Nobile be liable for any special, incidental or consequential damages. This warranty statement may be subject to modification in accordance with local laws, regulations and business practices.

*AutoPickPen, MagRo, PickPen and QuickPick are trademarks of Bio-Nobile Oy.*



Bio-Nobile Oy,  
Tykistökatu 4 B, P.O Box 36, FIN-20521 Turku, Finland  
tel +358 2 410 1100  
www.bio-nobile.com, [info@bio-nobile.com](mailto:info@bio-nobile.com)

# INSTRUCTIONS FOR USE



Bio-Nobile Oy  
P.O. Box 36  
FIN-20521 Turku, Finland  
Tel. +358-2-410 1100  
Fax: +358-2-410 1123  
www.bio-nobile.com

## QuickPick™ SML Plant DNA

- 53002 • Plant DNA purification kit, 8 preps
- 53012 • Plant DNA purification kit, 24 preps
- 53022 • Plant DNA purification kit, 96 preps



	Make sure that there are enough tips for the APP
Pump malfunction	Check that there are no tips attached to the pumps before run
	Make sure that there are enough tips for both pumps
Shaker	Check that the cables are connected
	Ensure the Heat Adapter is firmly placed on the shaker
	Use only new plates on the Heat Adapters (autoclaving may alter the plate dimensions)
	Check the shaking speed and maximum liquid volumes for each plate to prevent liquid spill
	Check the temperature for each reagent and volume
Labware	Check the plate dimensions
	Place the plates in a correct orientation (A1 is in the upper left corner)
No tips taken	Ensure that the tip boxes are tightly in place
	Ensure that the tip boxes are filled
	Use only Rainin tips

#### 8.4 Downstream applications

Downstream applications	
High absorbance at 320 nm	Eluates may contain Magnetic Particles. Centrifuge the sample for 1 min with maximum speed. Wash the Magnetic Particles with bound DNA properly in Wash Buffers
No PCR product	Repeat purification using fresh sample Residual ethanol carried from Wash Buffer 1 Sequencing enzymes, polymerases and other Mg <sup>2+</sup> - dependent enzymes: EDTA inhibits the enzymes, use water as elution buffer Optimize the DNA amount for the application Wash the Magnetic Particles containing the bound DNA properly in Wash Buffers
RNA contamination	Add RNase A to sample before lysis step Optimize the amount of RNase A used

Purified DNA too concentrated / too diluted	
Too small elution volume	Use more Elution Buffer to achieve optimal concentration Dilute final eluate by adding sufficient volume of Elution Buffer
Too large elution volume	Use less Elution Buffer to achieve optimal concentration

## 8.2 Manual Tools

Magnetic Particles are not collected from the suspension	
Magnet inside	Push the magnet out
No tip	Use PickPen® tip
Sample too viscous	Make sure to use correct sample amounts and that homogenizing and lysis steps are adequately performed Decrease the amount of sample material Dilute the sample and use Lysis Buffer, Proteinase K solution and Binding Buffer in correct ratio
Visible Magnetic Particles in all vessels/wells	Increase the collecting time
Visible Magnetic Particles in Elution Buffer	Centrifuge the sample for 1 min with maximum speed Increase the collecting time

Particles not released from the tip	
Magnet out	Pull the magnet inside
No tip	Use PickPen® tip
Sample amount too high	Make sure to use correct sample amounts and that the homogenization and lysis steps are adequately performed Decrease the amount of sample material Dilute the sample and use Lysis Buffer, Proteinase K solution and Binding Buffer in correct ratio Increase the suspension time and rub the PickPen® tip with Magnetic Particles against the vessel wall
Too small elution volume	Use larger volume

## 8.3 MagRo™ 8-M robotic workstation

MagRo™ 8-M does not work	
Instrument connections	Check that instrument is connected to the main power source and that all the cables are connected Check that the power is turned on both in the back and in the front of the instrument
Home-made process or macro doesn't start	Check the process in Edit process or Edit macro Check that all the parameters are correctly written

Magro™ 8-M protocol problems	
No liquid aspirated	The tip might be blocked or broken. Do not reuse tips The pump piston may have some liquid inside, clean the pump Some reagents might have air bubbles that interfere with the aspiration
"No liquid" signal	Check that reagent bottles contain liquids. Fill the bottles and continue the process.
The tips were not dropped in to waste box	Empty the waste box after each run Check that the waste slide is positioned in the right edge
Gripper malfunction	Check that the grippers are correctly placed on the holder
APP malfunction	Check that the APP is correctly placed on the holder with no tips attached

## TABLE OF CONTENTS:

<b>1 INTRODUCTION</b> .....	<b>4</b>
1.1 Principle of the method .....	4
<b>2 SPECIFICATIONS</b> .....	<b>4</b>
<b>3 KIT CONTENTS</b> .....	<b>4</b>
3.1 Reagents of the SML kits .....	4
3.2 Scaling of sample amount .....	5
<b>4 SAMPLE PREPARATION</b> .....	<b>5</b>
4.1 DNA yield from plant tissues .....	5
4.2 Homogenization of plant material .....	5
<b>5 PICKPEN® TIPS</b> .....	<b>7</b>
<b>6 PROTOCOLS FOR MANUAL PICKPEN® 1-M AND 8-M TOOLS</b> .....	<b>7</b>
6.1 PickPen® 1-M protocol .....	7
6.2 PickPen® 8-M protocol .....	9
<b>7 PROTOCOLS FOR MAGRO™ 8-M ROBOTIC WORKSTATION</b> .....	<b>12</b>
7.1 Notes for working with MagRo™ 8-M .....	12
7.2 Executing of MagRo™ 8-M protocols (macros) .....	12
7.3 MagRo™ 8-M purification from 25 mg of sample, 1 - 24 preps .....	14
7.4 MagRo™ 8-M purification from 25 mg sample, 25 - 48 preps .....	15
7.5 MagRo™ 8-M purification from 25 mg sample, 49 - 96 preps .....	16
7.6 MagRo™ 8-M purification from 50 mg sample, 1 - 24 preps .....	17
7.7 MagRo™ 8-M purification from 50 mg sample, 25 - 48 preps .....	18
7.8 MagRo™ 8-M purification from 50 mg sample, 49 - 96 preps .....	19
7.9 MagRo™ 8-M purification from 100 mg sample, 1 - 24 preps .....	20
7.10 MagRo™ 8-M purification from 100 mg sample, 25 - 48 preps .....	21
7.11 MagRo™ 8-M lysis step for 1 - 25 mg sample .....	22
7.12 MagRo™ 8-M lysis step for 26 - 50 mg sample .....	23
7.13 MagRo™ 8-M lysis step for 51 - 100 mg plant tissue sample .....	24
<b>8 TROUBLESHOOTING GUIDE</b> .....	<b>25</b>
8.1 Reagents .....	25
8.2 Manual Tools .....	26
8.3 MagRo™ 8-M robotic workstation .....	26
8.4 Downstream applications .....	27
<b>9 STORAGE AND STABILITY</b> .....	<b>28</b>
<b>10 WARNINGS AND LIMITATIONS</b> .....	<b>28</b>
<b>11 DISCLAIMERS AND WARRANTIES</b> .....	<b>28</b>

## 1 INTRODUCTION

These are the instructions for use for the QuickPick™ SML Plant DNA purification kits. Please read the entire instructions carefully before starting the work. Also refer to the MagRo™ 8-M robotic workstation operating manual or PickPen® 1-M or PickPen® 8-M instructions for use.

The QuickPick™ SML Plant DNA purification kits provide fast and simple means of purifying genomic DNA from a variety of plants or their organelles. The technique does not require any organic solvents and eliminates the need for repeated centrifugation, vacuum filtration or column separation. The size of DNA purified using the QuickPick™ SML Plant DNA purification kits is typically at least 30 kbp. DNA fragments of this length denature completely during thermal cycling and can be used for downstream applications such as PCR amplifications, restriction enzyme digestions and sequencing.

The reagent volumes can be scaled up or down to be used with different sample amounts either with the PickPen® manual tools or the MagRo™ 8-M robotic workstation.

### 1.1 Principle of the method

DNA in the plant tissue sample is released using Proteinase K solution and Lysis Buffer. Released DNA is bound to Magnetic Particles in the presence of Binding Buffer. Magnetic Particles with the bound DNA are washed three times with the Wash Buffer. The DNA is then eluted from the Magnetic Particles with the Elution Buffer.

## 2 SPECIFICATIONS

Table 1: Specifications for QuickPick™ SML Plant DNA purification kit.

Plant sample (leaf)	Yields of DNA vs. sample amount <sup>(1)</sup>		
	25 mg	50 mg	100 mg
<i>Arabidopsis thaliana</i>	Up to 1 µg	Up to 2 µg	Up to 4 µg
<i>Lactuca sativa</i>	Up to 1.5 µg	Up to 3 µg	Up to 6 µg
<i>Hordeum vulgare</i>	Up to 3 µg	Up to 6 µg	Up to 12 µg
<i>Ocimum basilicum</i>	Up to 2.5 µg	Up to 5 µg	Up to 10 µg
<b>Typical purity<sup>(2)</sup></b>	≥ 1.7		
<b>Size of purified DNA</b>	≥ 30 kbp		

<sup>1</sup>DNA yield varies greatly between different sources of sample material.

<sup>2</sup>Ratio of absorbance at 260/280 nm is corrected with absorbance at 320 nm.

## 3 KIT CONTENTS

### 3.1 Reagents of the SML kits

Reagent:	8 preps	24 preps	96 preps
Plant DNA MagaZorb™ Magnetic Particles <sup>(1,2)</sup>	40 µl	170 µl	540 µl
Plant DNA Proteinase K solution	40 µl	250 µl	700 µl
Plant DNA Lysis Buffer	600 µl	3.2 ml	8.5 ml
Plant DNA Binding Buffer <sup>(2)</sup>	1 ml	4.25 ml	13.5 ml
Plant DNA Wash Buffer <sup>(2)</sup>	6 ml	22 ml	2 x 40 ml
Plant DNA Elution Buffer	1 ml	7 ml	22 ml

<sup>1</sup>MagaZorb™ technology is a trademark of Cortex Biochem Inc.

<sup>2</sup>Reagents contain 0.02% NaN<sub>3</sub>

## 8 TROUBLESHOOTING GUIDE

### 8.1 Reagents

Low DNA yield	
Poor sample preparation	<p>Make sure that the sample is totally homogenized. Increase the homogenization time or try another homogenization method.</p> <p>If liquid nitrogen is used: Don't let the plant tissue samples to thaw during or after homogenization</p> <p>Cut the sample into small pieces before homogenization</p>
Too small sample amount	Use larger sample amounts or smaller reagent amounts (see Chapter 3.2 "Scaling of sample amount")
Too large sample amount	Use smaller sample amount. Too high sample amount interfere with the purification. For larger sample amounts use more reagents (see Chapter 3.2 "Scaling of sample amount")
Insufficient lysis	<p>Add correct volume or increase the volume of Proteinase K solution</p> <p>Use increased lysis time and/or improve mixing</p> <p>Make sure to mix plant tissue sample, Lysis Buffer and Proteinase K solution thoroughly by pulse-vortexing before starting the lysis incubation</p> <p>Ensure that the heating step is done at 65°C</p> <p>Use the appropriate heating adapter for the sample 96-well plate</p>
Insufficient binding	<p>Make sure the Magnetic Particles are in suspension during incubation</p> <p>Suspend the Magnetic Particles gently by pipetting up and down during binding step</p> <p>Increase the binding time</p> <p>Make sure the volume of the Binding Buffer correlates with the sample amount used</p>
No shaking during incubations	Make sure the Magnetic Particles are in suspension during incubations
Insufficient washes	<p>Increase the washing time in each Wash Buffer</p> <p>Use eluate as the sample and repeat the purification</p>
Inappropriate elution buffer	DNA will only be eluted in the presence of low salt (e.g. 10 mM Tris-Cl, pH 8.5) or water. Check the pH and salt concentration of the elution buffer.
Insufficient elution	<p>Increase the elution time</p> <p>Ensure that Magnetic Particles are in suspension during elution</p> <p>Continue elution until Magnetic Particles are uniformly dispersed</p> <p>Use heating during elution (max +65°C)</p>
Magnetic Particles	<p>Optimize the amount of Magnetic Particles</p> <p>Use only Plant DNA MagaZorb™ Magnetic Particles</p> <p>Do not freeze Magnetic Particles</p> <p>Make sure that Magnetic Particles are uniformly suspended before dispensing</p>

### 7.13 MagRo™ 8-M lysis step for 51 - 100 mg plant tissue sample

#### Specifications

Sample material amount:	51 - 100 mg
Preps in one run:	1 – 96
Macro name:	Plant_100mg_lysis

#### Material required

- 96 deep-well homogenization device for plant tissue samples
- Two sterile 96 deep-well plates
- Centrifuge for 96 deep-well plates
- Heat Adapter for 96 deep-well plates

#### Process

- Disrupt plant tissue samples with the homogenization device for 96 deep-well plate.
- Place the 96 deep-well plate on MagRo™ 8-M according to the deck layout. Start the macro Plant\_100mg\_lysis.
- After finishing the macro a Message box appears showing that the run is finished. Press OK.
- Remove the lysed plant tissue samples from MagRo™ 8-M.
- Centrifuge the microplate for 5 minutes at 18,000 x g. Gently transfer the supernatant from each well into the respective columns of sterile 96 deep-well plate.
- Continue with the MagRo™ 8-M purification protocol (for example Plant\_100mg\_24).

#### Deck layout

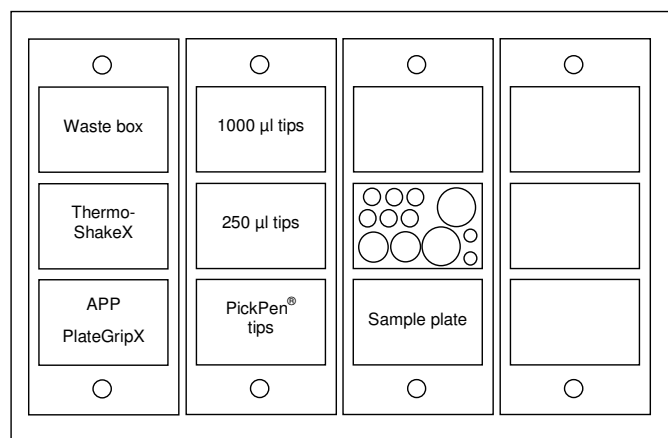

The reagents for QuickPick™ SML Plant DNA purification kits can also be bought separately:

Reagent:	Volume	Product No:
QuickPick™ XL Plant DNA MagaZorb™ Magnetic Particles <sup>(1,2)</sup>	2 ml	53100
QuickPick™ XL Plant DNA Proteinase K solution	2.8 ml	53200
QuickPick™ XL Plant DNA Lysis Buffer	32 ml	53400
QuickPick™ XL Plant DNA Binding Buffer <sup>(2)</sup>	50 ml	53300
QuickPick™ XL Plant DNA Wash Buffer <sup>(2)</sup>	300 ml	53500
QuickPick™ XL Plant DNA Elution Buffer	85 ml	53600

<sup>1</sup>MagaZorb™ technology is a trademark of Cortex Biochem Inc.

<sup>2</sup>Contains 0.02% NaN<sub>3</sub>.

### 3.2 Scaling of sample amount

For both manual and automated protocols the sample amount can be scaled yielding to different number of preparations (Table 2) and reagent consumption. The reagent volumes are linearly dependent on the used sample amount. The reagent volumes for the manual purifications are shown in Tables 3 and 4 (see Chapter 6 "Protocols for manual PickPen® 1-M and 8-M tools"). In MagRo™ 8-M robotic workstation protocols the reagent volumes are adjusted to be suitable for automation.

Table 2: The effect of sample amount to number of preparations and reagent volumes for the purifications with QuickPick Plant DNA SML kits.

Sample amount	Number of preps		
	53002 <sup>(1)</sup>	53012	53022
25 mg	16	48	192
50 mg	8	24	96
100 mg	4	12	48

<sup>1</sup>For manual use only.

## 4 SAMPLE PREPARATION

### 4.1 DNA yield from plant tissues

The DNA content varies widely between different plant materials. For example, a tissue sample comprised of small cells will have a higher cell density, and therefore is likely to contain more nucleic acids than a sample of the same size which is comprised of larger cells. In addition, DNA content depends on the haploid genome size and the ploidy of the sample. For example, *Arabidopsis thaliana* has a small diploid genome and correspondingly lower DNA yields than wheat which has a large hexaploid genome.

When possible, it is preferable to harvest young plant material (e.g. expanding leaves or needles). Nucleic acid yields from young plant tissues are often higher than from old plant tissue, because young plant tissue generally contains more cells than the same amount of older plant tissue. In addition, young plant tissue of the same weight contains fewer metabolites (such as polyphenolics, polysaccharides and flavones) which can affect the performance of downstream applications.

### 4.2 Homogenization of plant material

Plant tissues should be homogenized before they are used as the sample in the purification protocol. Complete disruption of cell walls, plasma membranes, and organelle membranes is essential to release all the nucleic acids from the plant tissue. Insufficient homogenization of starting material will lead to low DNA yield. Cell wall properties vary widely between species and proper homogenization method should be applied to achieve complete disruption. The homogenization of plant tissue can be performed by

mechanical grinding with different types of bead mills or with liquid nitrogen. Other homogenization methods can also be used.

#### Homogenization with liquid nitrogen using mortar and pestle

One of the most common homogenization methods involves freezing plant tissue sample in liquid nitrogen and grinding with a mortar and pestle.

1. Freeze plant tissue sample in liquid nitrogen immediately after harvesting. Do not let the sample to thaw at any time during homogenization.
2. Precool equipments by pouring liquid nitrogen into mortar and placing the pestles grinding end in the liquid nitrogen.
3. Place the frozen plant tissue sample in mortar and grind until fine whitish powder results.
4. Add liquid nitrogen as necessary but be careful not to spill the sample out of the mortar.
5. Using a precooled spatula transfer the powdered plant tissue sample into a precooled tube. Use several tubes for large samples to avoid thawing. Ensure all liquid nitrogen has evaporated before closing the tube(s).
6. If plant tissue sample is not processed immediately the tube should be kept on dry ice or liquid nitrogen or stored at -80°C, to prevent the sample from thawing after evaporation.
7. If plant tissue sample is processed immediately after homogenization, add the appropriate volume of Plant DNA Lysis Buffer and Proteinase K solution before the sample thaws.
8. Proceed with the purification protocol.

#### Homogenization using bead mill.

A bead mill homogenizes plant tissue samples by rapid agitation with tungsten carbide or steel beads. Homogenization is caused by the shearing and crushing action of the beads as they collide with the plant tissue sample. When using fresh plant leaf tissues, most samples can be homogenized in the presence of Lysis Buffer. Alternatively, homogenization of frozen plant material can be performed without Lysis Buffer if the beads and disruption vessel are precooled with liquid nitrogen. Plant tissue samples should be homogenized in the presence of either Lysis Buffer or liquid nitrogen to preserve the quality of the contained nucleic acids.

1. Weigh plant tissue samples into tubes.
2. Add appropriate volume of Plant DNA Lysis Buffer and 1 - 2 steel or Tungsten beads into each tube.
3. Close tubes tightly.
4. Homogenize for 1 - 2 minutes until the plant tissue samples seem homogenous.
5. Collect the beads away from the homogenates.
6. Pipette appropriate volume of Proteinase K solution into homogenates.
7. Proceed immediately with the purification protocol.

#### Homogenization using tissue grinder

A tissue grinder homogenizes plant tissue samples efficiently and helps in rapid preparation of the sample homogenates. When using fresh plant leaf tissues, most samples can be homogenized in the presence of Lysis Buffer. Alternatively, homogenization of frozen plant materials can be performed without Lysis Buffer if the disruption vessel is precooled with liquid nitrogen. Plant tissue samples should be homogenized in the presence of either Lysis Buffer or liquid nitrogen to preserve the quality of the contained nucleic acids.

1. Weigh plant tissue samples into tubes.
2. Add liquid nitrogen into the tubes but be careful not to spill the samples out of the tubes.
3. Homogenize the plant tissue samples for 1 - 2 minutes with the tissue grinder (for example Pellet Pestle or equivalent device) until fine whitish powder results.
4. Ensure all liquid nitrogen has evaporated before closing the tubes (Do not let the plant tissue samples thaw).
5. If plant tissue samples are not processed immediately the tubes should be kept on dry ice or liquid nitrogen or stored at -80°C, to prevent the samples from thawing after evaporation.
6. If plant tissue samples are processed immediately after homogenization, add appropriate volumes of Plant DNA Lysis Buffer and Proteinase K solution before the samples thaw.
7. Proceed with the purification protocol.

## 7.12 MagRo™ 8-M lysis step for 26 - 50 mg sample

### Specifications

Sample material amount:	26 - 50 mg
Preps in one run:	1 – 96
Macro name:	Plant_50mg_lysis

### Material required

1. 96-well microplate homogenization device for plant tissue samples
2. Two sterile 96-well microplates
3. Centrifuge for 96-well microplates
4. Heat Adapter for 96-well microplates

### Process

1. Disrupt plant tissue samples with the 96-well microplate homogenization device.
2. Place the 96-well microplate on MagRo™ 8-M according to the deck layout. Start the macro Plant\_50mg\_lysis.
3. After finishing the macro a Message box appears showing that the run is finished. Press OK.
4. Remove the lysed plant tissue samples from MagRo™ 8-M.
5. Centrifuge the 96-well microplate for 5 minutes at 18,000 x *g*. Gently transfer the supernatant from each well into the respective columns of sterile 96-well microplate.
6. Continue with MagRo™ 8-M purification protocol (for example Plant\_50mg\_48).

### Deck layout

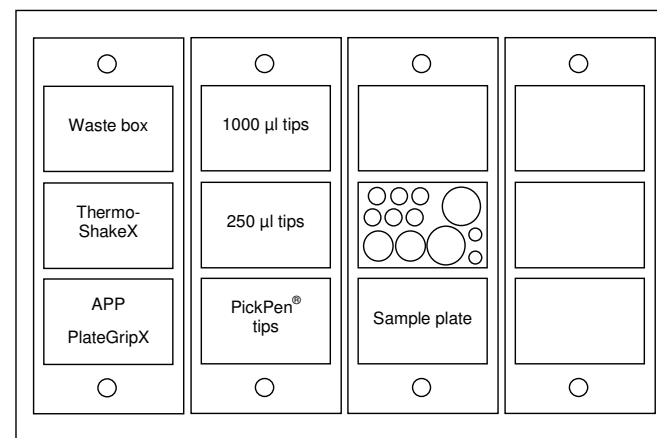

## 7.11 MagRo™ 8-M lysis step for 1 - 25 mg sample

### Specifications

Sample material amount: 1 - 25 mg  
 Preps in one run: 1 – 96  
 Macro name: Plant\_25mg\_lysis

### Material required

1. 96-well microplate homogenization device for plant tissue samples
2. Two sterile 96-well microplates
3. Centrifuge for 96-well microplates
4. Heat Adapter for 96-well microplates

### Process

1. Disrupt plant tissue samples with the 96-well microplate homogenization device.
2. Place the 96-well microplate on MagRo™ 8-M according to the deck layout. Start the macro Plant\_25mg\_lysis.
3. After finishing the macro a Message box appears showing that the run is finished. Press OK.
4. Remove the lysed plant tissue samples from MagRo™ 8-M.
5. Centrifuge the 96-well microplate for 5 minutes at 18,000 x g. Gently transfer the supernatant from each well into the respective columns of sterile 96-well microplate.
6. Continue with MagRo™ 8-M purification protocol (for example Plant\_25mg\_48).

### Deck layout

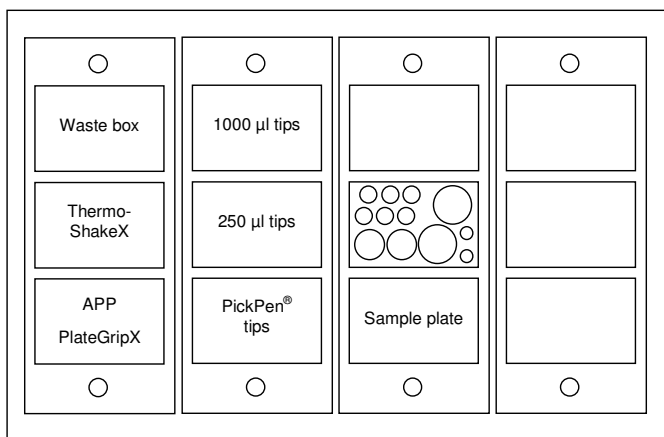

## 5 PICKPEN® TIPS

The tips packed in bulk quantities in plastic bags are not sterile. Sterilize the tips in PickPen® Tip box by autoclaving.

## 6 PROTOCOLS FOR MANUAL PICKPEN® 1-M AND 8-M TOOLS

### 6.1 PickPen® 1-M protocol

#### Notes

1. All solutions should be clear when used. If precipitates have formed, warm the solutions gently until the precipitates have dissolved.
2. Plant DNA MagaZorb™ Magnetic Particles should be mixed thoroughly just before pipetting. Vortexing of the Magnetic Particles is not recommended.
3. Repeat pipettors should not be used when dispensing Magnetic Particles.
4. If an RNA-free DNA preparation is required, add RNase solution into samples before starting the lysis step.
5. Water can also be used for elution.

#### Reagent volumes

Table 3: Reagent volumes for PickPen® 1-M purifications.

Reagent	Reagent volume per preparation		
	25 mg	50 mg	100 mg
Lysis Buffer	37.5 µl	75 µl	150 µl
Proteinase K solution	2.5 µl	5 µl	10 µl
Binding Buffer	62.5 µl	125 µl	250 µl
Magnetic Particles	2.5 µl	5 µl	10 µl
Wash Buffer	3 x 125 µl	3 x 250 µl	3 x 500 µl
Elution Buffer	25 µl	50 µl	100 µl

#### Material required

1. Sterile 1.5 – 2.0 ml tubes.
2. Pipettes and sterile micropipettor tips.
3. PickPen® 1-M tool and sterile PickPen® tips in box or in 8-Packs.
4. Microcentrifuge.

#### Protocol

1. Number tubes from 1 to 6.
2. Prepare the plant tissue sample according to Chapter 4 “Sample preparation”. Add appropriate volumes of Lysis Buffer and Proteinase K solution into the plant tissue sample (see Table 3). Mix thoroughly by pulse-vortexing and lyse the sample for 15 - 30 minutes at 65°C.



Incubate for 15 - 30 minutes at 65°C

1.

- During the lysis step, pipette QuickPick™ SML Plant DNA reagents (according to the Table 3) into tubes 2 - 6 as follows:

- Tube 2: Plant DNA MagaZorb™ Magnetic Particles and Plant DNA Binding Buffer
- Tube 3: Plant DNA Wash Buffer
- Tube 4: Plant DNA Wash Buffer
- Tube 5: Plant DNA Wash Buffer
- Tube 6: Plant DNA Elution Buffer

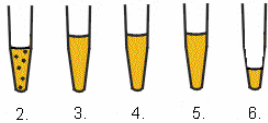

- Remove tube 1 from 65°C. Centrifuge the tube for 5 minutes at 18,000 x g. Gently transfer the supernatant into tube 2 (Binding Buffer, Magnetic Particles). Mix tube 2 gently and incubate at room temperature for 2 - 10 minutes. Mix the suspension continuously during this step (use a tube rotator or mix manually).

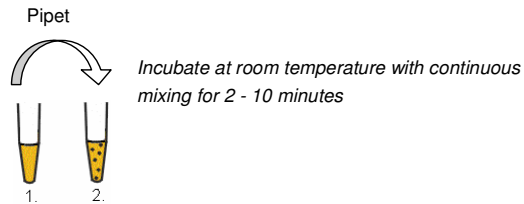

- Pick up the PickPen® tip with the PickPen® 1-M. Extend the magnet 2 - 3 times to check that the tip is firmly in place. Collect the Magnetic Particles from tube 2 with PickPen® 1-M and release them into tube 3 (Wash Buffer). Wash the Magnetic Particles by mixing the suspension gently for 10 - 20 seconds using the PickPen® tip. Note that the magnet has to be withdrawn at this point. To avoid the degradation of DNA only gentle mixing is recommended. Repeat the washing steps in tubes 4 and 5 (Wash Buffer).

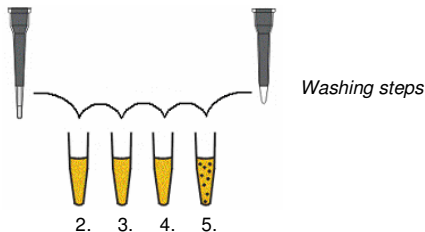

## 7.10 MagRo™ 8-M purification from 100 mg sample, 25 - 48 preps

### Specifications

- Sample material amount: 51 - 100 mg
- Preps in one run: 25 - 48
- Macro name: Plant\_100mg\_48

### Material required

- Samples in a 96 deep-well plate
- One sterile 96 deep-well plate
- One sterile 96-well microplate
- Sterile Rainin 250 µl and 1000 µl tips in DiTi boxes
- Sterile PickPen® tips in 96 tip box

### Deck layout

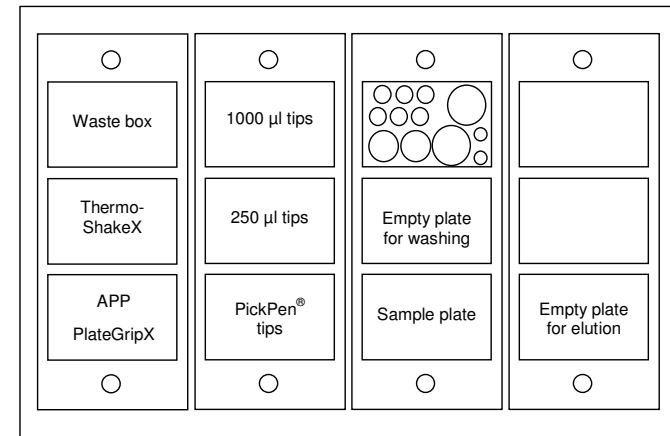

## 7.9 MagRo™ 8-M purification from 100 mg sample, 1 - 24 preps

### Specifications

Sample material amount: 51 - 100 mg  
 Preps in one run: 1 – 24  
 Macro name: Plant\_100mg\_24

### Material required

1. Samples in a 96 deep-well plate
2. One sterile 96 deep-well plate
3. Sterile Rainin 250 µl and 1000 µl tips in DiTi boxes
4. Reagent rack
5. Sterile PickPen® tips in 96 tip box

### Deck layout

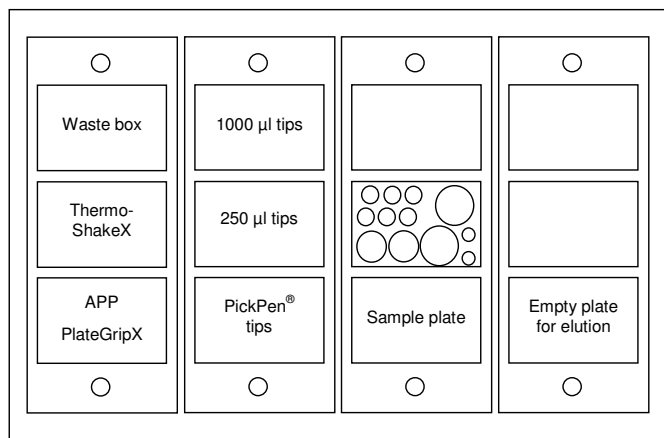

6. Collect the Magnetic Particles from tube 5 with PickPen® 1-M and release them into tube 6 (Elution Buffer). Mix tube 6 continuously and incubate at room temperature for 2 - 10 minutes (use a tube rotator or mix manually). During elution Magnetic Particles should disperse.

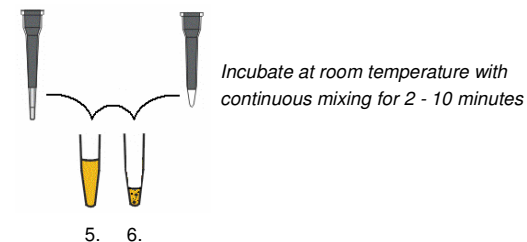

7. Collect the Magnetic Particles from tube 6 and discard them and the tip. The eluate in tube 6 containing the purified genomic DNA is ready to be used in downstream applications. If the purified DNA is not used on the same day, store at -20°C until use.

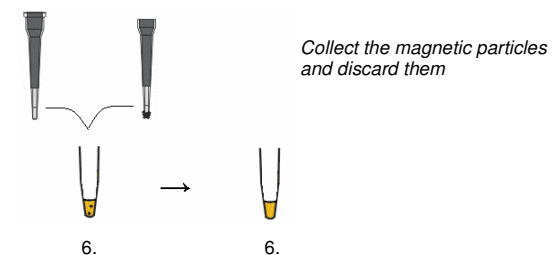

## 6.2 PickPen® 8-M protocol

### Notes

1. All solutions should be clear when used. If precipitates have formed, warm the solutions gently until the precipitates have dissolved.
2. Plant DNA MagaZorb™ Magnetic Particles should be mixed thoroughly just before pipetting. Vortexing of the Magnetic Particles is not recommended.
3. Repeat or 8-channel pipettors should not be used when dispensing Magnetic Particles.
4. If an RNA-free DNA preparation is required, add RNase solution into samples before starting the lysis step.
5. When using 96-well plates, the use of an orbital shaker is recommended. Adjust the speed to the highest possible level without causing liquid spill but still keep the Magnetic Particles in suspension.
6. Water can also be used for elution.

## Reagent volumes

Table 4: Reagent volumes for PickPen® 8-M purifications

Reagent	Reagent volume per preparation		
	25 mg	50 mg	100 mg
Lysis Buffer	37.5 µl	75 µl	150 µl
Proteinase K solution	2.5 µl	5 µl	10 µl
Binding Buffer	62.5 µl	125 µl	250 µl
Magnetic Particles	2.5 µl	5 µl	10 µl
Wash Buffer	3 x 125 µl	3 x 250 µl	3 x 500 µl
Elution Buffer	25 µl	50 µl	100 µl

## Material required

1. Sterile U-bottom 96-well plates (for example Nunc 500 µl 96-well microplate or 1 ml 96 deep-well plate, also available from Bio-Nobile Oy).
2. Pipettes and sterile micropipettor tips.
3. PickPen® 8-M tool and sterile PickPen® tips in box or in 8-Packs.
4. Microcentrifuge.
5. Orbital shaker for 96-well plates.

Table 5: Recommended plates for different sample amounts.

Sample amount (mg)	Recommended plate	Bio-Nobile Product No.
25	Greiner 96-well microplate, 300 µl, sterile	M1-650261
50	Nunc 96-well microplate, 500 µl, sterile	M1-267245
100	Nunc 96 deep-well plate, 1 ml, sterile	M1-260251

## Protocol

The following instructions are for 8 plant tissue samples. Samples are lysed in tubes and transferred into 96-well plates (U-bottom) where the rest of the protocol is carried out. The lysis step can also be performed in a thermal shaker using a suitable adapter for 96-well plates and if you have a centrifuge for these plates.

1. Prepare 8 plant tissue samples (number tubes from 1 to 8) according to Chapter 4 "Sample preparation". Add appropriate volumes of the Lysis Buffer and Proteinase K solution into the tubes according to the Table 2. Mix the tubes well by pulse-vortexing and lyse samples for 15 - 30 minutes at 65°C.



Incubate at 65°C for 15 - 30 minutes

## 7.8 MagRo™ 8-M purification from 50 mg sample, 49 – 96 preps

### Specifications

Sample material amount: 26 – 50 mg  
 Preps in one run: 49 – 96  
 Macro name: Plant\_50mg\_96

### Material required

1. Samples in a 96-well microplate
2. Four sterile 96-well microplates
3. Sterile Rainin 250 µl and 1000 µl tips in DiTi boxes
4. Reagent rack
5. Sterile PickPen® tips in 96 tip box

### Deck layout

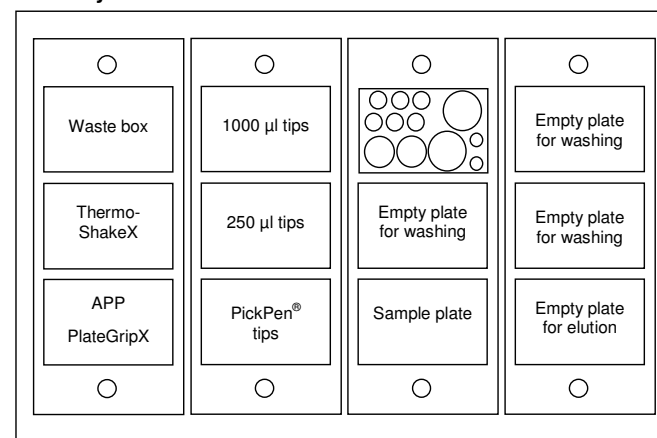

## 7.7 MagRo™ 8-M purification from 50 mg sample, 25 - 48 preps

### Specifications

Sample material amount: 26 – 50 mg  
 Preps in one run: 25 – 48  
 Macro name: Plant\_50mg\_48

### Material required

1. Samples in a 96-well microplate
2. Two sterile 96-well microplates
3. Sterile Rainin 250 µl and 1000 µl tips in DiTi boxes
4. Reagent rack
5. Sterile PickPen® tips in 96 tip box

### Deck layout

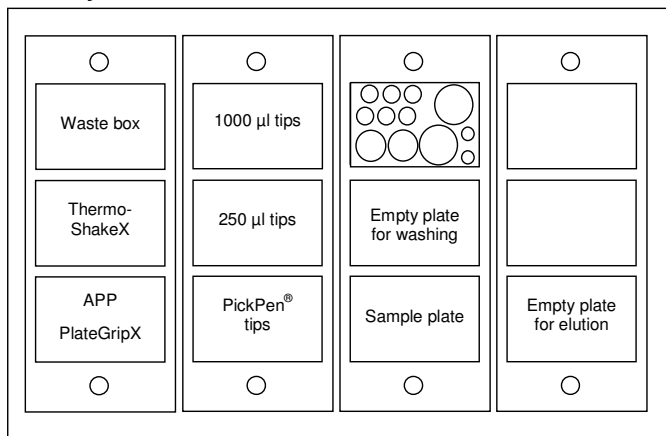

2. During the lysis step, pipette QuickPick™ SML Plant DNA reagents into 96-well plate columns 1 - 5 as follows (according to the Table 2).

Column 1: Plant DNA MagaZorb™ Magnetic Particles and Plant DNA Binding Buffer  
 Column 2: Plant DNA Wash Buffer  
 Column 3: Plant DNA Wash Buffer  
 Column 4: Plant DNA Wash Buffer  
 Column 5: Plant DNA Elution Buffer



3. Remove the tubes from 65°C. Centrifuge tubes for 5 minutes at 18,000 x g. Gently transfer the supernatant from each tube into the respective wells of column 1 (Binding Buffer, Magnetic Particles) by mixing the lysed sample and Magnetic Particles carefully by pipetting up and down few times. Mix the 96-well plate on the orbital shaker for 2 - 10 minutes at room temperature. Make sure that the Magnetic Particles are in suspension during this step.

Pipette

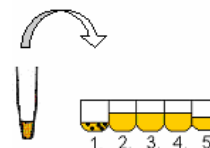

*Incubate for 2 - 10 minutes at room temperature with continuous mixing*

4. Pick up the PickPen® tips using PickPen® 8-M. Extend the magnets 2 - 3 times to check that the tips are firmly in place. Collect the Magnetic Particles from column 1 with PickPen® 8-M and release them into column 2 (Wash Buffer). Mix the suspensions gently for 10 – 20 seconds using the PickPen® tips. Note that the magnets have to be withdrawn at this point. To avoid the degradation of DNA only gentle mixing is recommended. Repeat the washing steps in columns 3 and 4 (Wash Buffer).

5. Collect the Magnetic Particles from column 4 with PickPen® 8-M and release them into column 5 (Elution Buffer). Mix the 96-well plate on the orbital shaker for 2 - 10 minutes at room temperature. Make sure that the Magnetic Particles are in a suspension during this step. During elution Magnetic Particles should disperse.

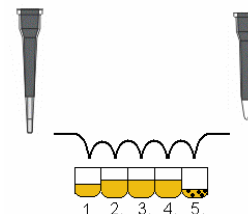

*Incubate for 2 - 10 minutes at room temperature with continuous mixing*

6. Collect the Magnetic Particles from column 5 and discard them and the tips. The eluates in column 5 contain the purified genomic DNA and are ready to be used in downstream applications. If the purified DNA is not used on the same day, store at -20°C until use.

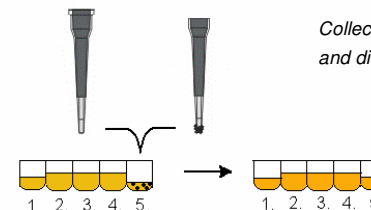

*Collect the Magnetic Particles and discard them*

## 7 PROTOCOLS FOR MAGRO™ 8-M ROBOTIC WORKSTATION

### 7.1 Notes for working with MagRo™ 8-M

- All solutions should be clear when used. If precipitates have formed, warm the solutions gently until the precipitates have dissolved.
- Mix the MagaZorb™ Magnetic Particles bottle thoroughly (do not vortex) and empty it into the Binding Buffer bottle. Store this MP / Binding Buffer mix at room temperature with other reagent bottles. If using XL Reagents refer to the QuickPick™ XL Plant DNA Reagents instructions for use.
- Before starting any process make sure that:
  - You have enough of disposable tips (DiTi) for the AutoPickPen™ (APP) and pumps.
  - You have enough reagents in the reagent bottles.
  - The Tip Waste Module is empty.
  - The APP and the gripper are correctly positioned in their place.
  - There are no tips attached on the APP or the pumps.
  - Correct Heat Adapter is properly placed on the Thermo-ShakeX.
- See also MagRo™ 8-M manual for proper use of the instrument. There are more instructions on how to use the software and how to execute processes.
- If an RNA-free DNA preparation is required, add RNase solution into plant tissue sample before starting the lysis step.
- Water can also be used for elution.
- Use sterile U-bottom 96-well plates (300, 500 µl and 1 ml) for purification (see Table 5).

### 7.2 Executing of MagRo™ 8-M protocols (macros)

- Switch on the instrument and start the Lirix software.
- Each macro has an individual name. Look for correct macro name in the Table 6. To find a macro from MagRo™ 8-M open Lirix Shortcuts and click Start Macro icon.



Table 6: The names of the macros for MagRo™ 8-M used with QuickPick™ SML Plant DNA purification kits.

Preps	Macro names		
	25 mg	50 mg	100 mg
1 – 24	Plant_25mg_24 (Chapter 7.3)	Plant_50mg_24 (Chapter 7.6)	Plant_100mg_24 (Chapter 7.9)
25 – 48	Plant_25mg_48 (Chapter 7.4)	Plant_50mg_48 (Chapter 7.7)	Plant_100mg_48 (Chapter 7.10)
49 – 96	Plant_25mg_96 (Chapter 7.5)	Plant_50mg_96 (Chapter 7.8)	Not available
	Plant_25mg_lysis <sup>(1)</sup> (Chapter 7.11)	Plant_50mg_lysis <sup>(1)</sup> (Chapter 7.12)	Plant_100mg_lysis <sup>(1)</sup> (Chapter 7.13)

<sup>1</sup>Plant tissue samples can also be lysed on the MagRo™. A 96-well plate centrifuge and homogenization devices are needed.

- Click the correct macro name in "Macro Names" –list to open the process layout in the window.

### 7.6 MagRo™ 8-M purification from 50 mg sample, 1 - 24 preps

#### Specifications

Sample material amount:	26 – 50 mg
Preps in one run:	1 – 24
Macro name:	Plant_50mg_24

#### Material required

- Samples in a 96-well microplate
- Onw sterile 96-well microplate
- Sterile Rainin 250 µl and 1000 µl tips in DiTi boxes
- Reagent rack
- Sterile PickPen® tips in 96 tip box

#### Deck layout

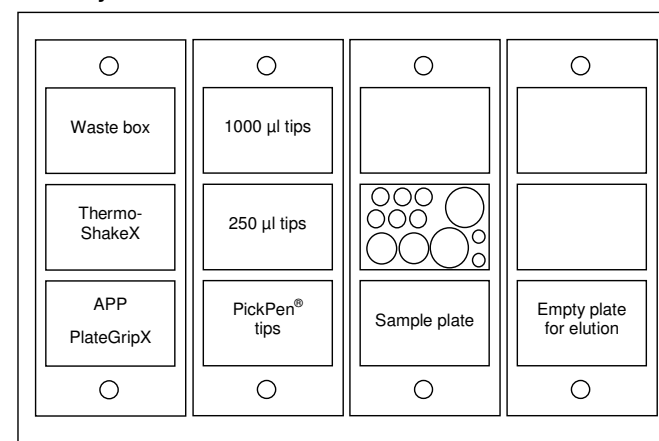

## 7.5 MagRo™ 8-M purification from 25 mg sample, 49 - 96 preps

### Specifications

Sample material amount:	1 – 25 mg
Preps in one run:	49 – 96
Macro name:	Plant_25mg_96

### Material required

1. Samples in a 96-well microplate
2. Four sterile 96-well microplates
3. Sterile Rainin 250 µl and 1000 µl tips in DiTi boxes
4. Reagent rack
5. Sterile PickPen® tips in 96 tip box

### Deck layout

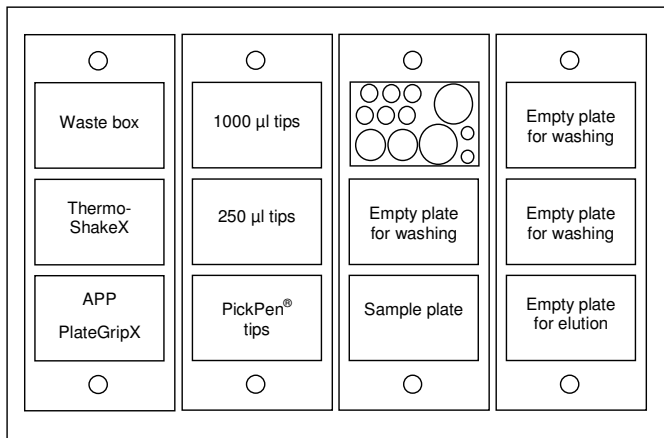

4. Place trays, tip boxes, plates and racks as described in Chapters 7.3 to 7.10.
5. Mix all reagent bottles, open and place them in the Reagent rack in following positions:

Position 10:	MP/Binding Buffer mix
Positions 13 and 19:	Wash Buffer
Position 17:	Elution Buffer

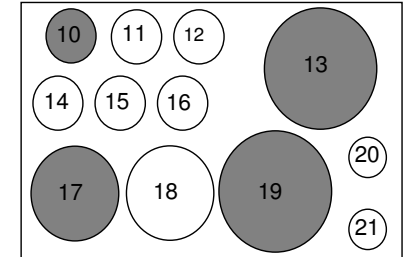

**NOTE:** If preparing up to 48 samples, only one bottle of each reagent is needed for the run (place in positions 10, 17 and 19).

6. Prepare plant tissue samples according to Chapter 4 "Sample preparation". After homogenization, add appropriate volumes of Lysis Buffer and Proteinase K solution into samples according to the Table 3. Mix samples well by pulse-vortexing and lyse samples for 15 - 30 minutes at 65°C.
7. After lysis step centrifuge samples for 5 minutes at 18,000 x g. Transfer the supernatants gently into the sterile U-bottom 96-well plate. Note: the Lysis step can also be done with MagRo™ 8-M if a 96-well plate centrifuge and homogenization devices are available. See Chapters 7.11 - 7.13.
8. Start the macro by double-clicking the macro name.
9. A dialog window opens, in which you may enter the run specific information. You can also choose to start with the refilled DiTi boxes by ticking the box. Press Next to continue.
10. The instrument now asks you to verify that all the items placed on the deck correspond to the displayed layout. Press Start Run to continue.
11. A window asking for number of samples appears. Enter the number of samples and press OK. MagRo™ 8-M starts the macro.
12. After finishing the macro, a Message box appears notifying that the run is finished. Press OK.
13. The eluates containing the purified genomic DNA (deck tray 4 at position 3) are ready to be used for downstream applications.
14. If the purified DNA is not used on the same day, store at -20°C until use.

### 7.3 MagRo™ 8-M purification from 25 mg of sample, 1 - 24 preps

#### Specifications

Sample material amount: 1 – 25 mg  
 Preps in one run: 1 – 24  
 Macro name: Plant\_25mg\_24

#### Material required

1. Samples in a 96-well microplate
2. One sterile 96-well microplate
3. Sterile Rainin 250 µl and 1000 µl tips in DiTi boxes
4. Reagent rack
5. Sterile PickPen® tips in 96 tip box

#### Deck layout

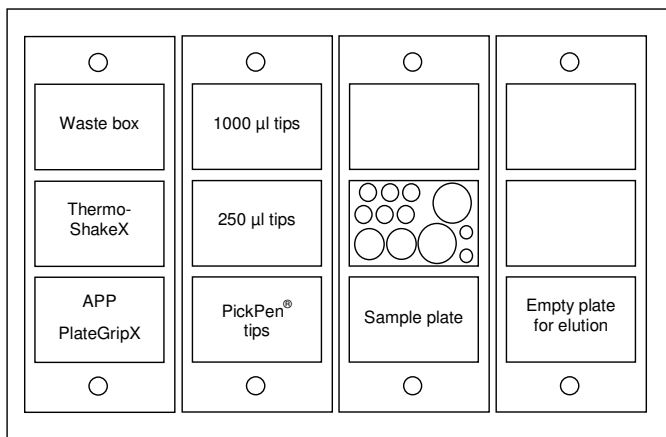

### 7.4 MagRo™ 8-M purification from 25 mg sample, 25 - 48 preps

#### Specifications

Sample material amount: 1 – 25 mg  
 Preps in one run: 25 – 48  
 Macro name: Plant\_25mg\_48

#### Material required

1. Samples in a 96-well microplate
2. Two sterile 96-well microplates
3. Sterile Rainin 250 µl and 1000 µl tips in DiTi boxes
4. Reagent rack
5. Sterile PickPen® tips in 96 tip box

#### Deck layout

